

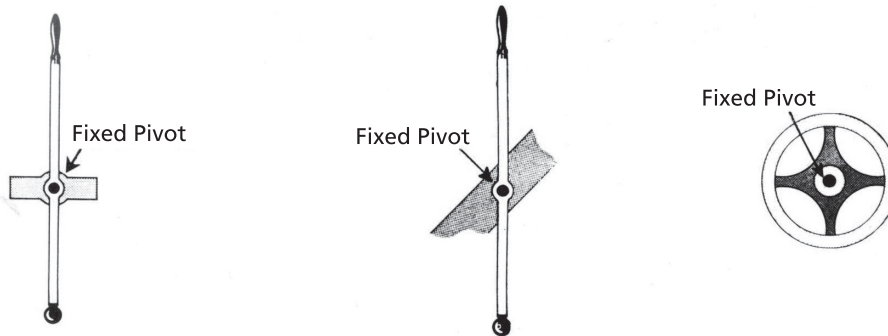

For this test, you need to understand what a pivot is. A pivot is a pin or axle around which a lever or wheel can turn. A **fixed pivot** is a pin or axle around which a lever or wheel can turn, but the fixed pivot itself **does not move**. A fixed pivot is indicated by a black dot, as demonstrated below in this example.

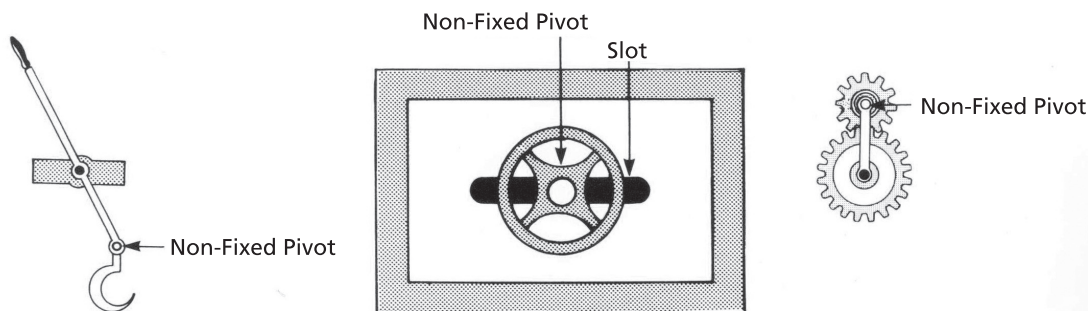

A **non-fixed pivot** is also a pin or axle around which a lever or wheel can turn, but the non-fixed pivot itself **can move**. A non-fixed pivot is indicated by a clear dot, as demonstrated in this example.



SAMPLE 1

When wheel Y turns clockwise, as shown by the arrow, wheel Z will

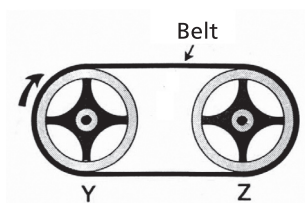

- A turn clockwise.
- B turn anticlockwise.
- C turn to and fro.
- D stay still.

SAMPLE 2

When handle H is pulled to the right, as shown by the arrow, end E will

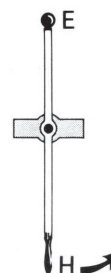

- A move to the left.
- B move to the right.
- C move to and fro.
- D stay still.